

## Safety switch TP with guard locking



- ▶ Mechanical release on the front
- ▶ Increased horizontal overtravel
- ▶ Optional without guard lock monitoring



### Mechanical release

Is used for releasing the guard locking with the aid of a tool. To protect against tampering, the mechanical release is sealed with sealing lacquer.

### Guard locking types

**TP3** Closed-circuit current principle, guard locking by spring force. Release by control of AS-i output 0.

**TP4** Open-circuit current principle, guard locking by control of AS-i output 0. Release by spring force.

### Control of the interlocking solenoid

The interlocking solenoid is controlled by the control system via AS-Interface bus bit D0. Simple connection to the bus is sufficient for process protection. For personal protection, further measures must be taken to ensure safe power switching. The 24V connection can be switched safely for personal protection.

### AS-Interface inputs version AS1

- ▶ **D0, D1** Door monitoring contact SK
- ▶ **D2, D3** Solenoid monitoring contact UK

### AS-Interface inputs version AS2

- ▶ **D0, D1** Door monitoring contact SK 1
- ▶ **D2, D3** Door monitoring contact SK 2

Evaluation is performed via a safety monitor.

### AS-Interface outputs

- ▶ **D0** Interlocking solenoid
- ▶ **D1** Red LED
- ▶ **D2** Green LED

### LED function display

- ▶ The *Power* LED indicates the operating voltage at the bus.
- ▶ The *Fault* LED shows if a fault has been detected on the AS-Interface bus.
- ▶ The green and the red LEDs can be optionally controlled with bits D1 and D2 by the control via the bus.

**Plug connector M12**  
4-pin

### Dimension drawing

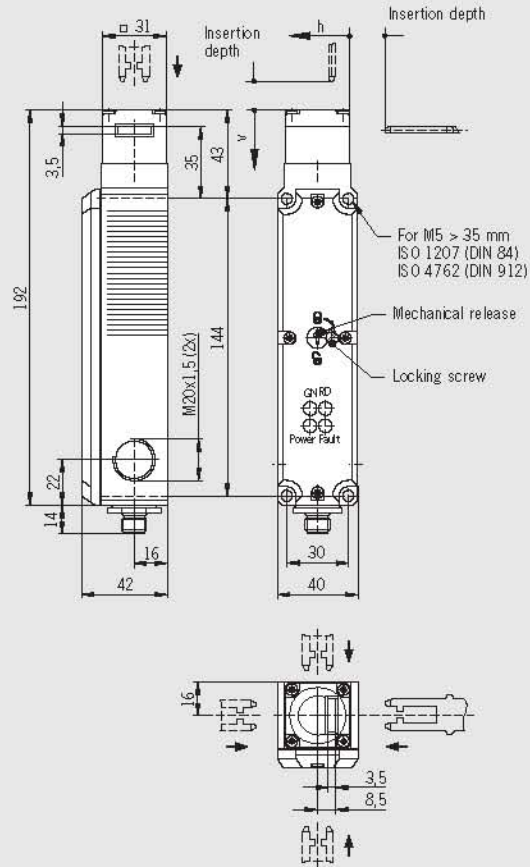

Please order actuator separately (see catalog of Safety Switches with Plastic Housings)

### Ordering table

Series	Connection	Guard locking	Switching element	Version	Order No./item
TP	SEM4 Plug connector M12	3 Mechanical	SK: 1 NC ⊖ UK: 1 NC ⊖	<b>AS1</b> With guard lock monitoring	<b>088 256</b> TP3-4141A024SEM4AS1
		4 Electrical	SK: 1 NC ⊖ UK: 1 NC ⊖	<b>AS1</b> With guard lock monitoring	<b>088 257</b> TP4-4141A024SEM4AS1
			SK: 2 NC ⊖	<b>AS2</b> Without guard lock monitoring	<b>091 676</b> TP4-4141A024SEM4AS2

## Safety switch TP... with guard locking and guard lock monitoring



Switch			
Parameter	Value		Unit
Housing material	Reinforced thermoplastic		
Mechanical life	1 x 10 <sup>6</sup> operating cycles		
Ambient temperature	- 20 ... + 55		°C
Weight	approx. 0.5		kg
Approach speed, max.	20		m/min
Actuating force	10		N
Extraction force (not locked)	20		N
Retention force	10		N
Locking force, max.	1300		N
Locking force F <sub>20</sub> in accordance with test principles GSET-19	1000		N
Insertion depth (necessary minimum travel + permissible overtravel)	Standard actuator	Overtravel actuator	
Approach direction side (h)	28 + 2	28 + 7	mm
Approach direction from top (v)	29.5 + 1.5	-	mm
<b>Interlocking solenoid</b>			
Solenoid operating voltage (auxiliary power on black AS-interface cable)	24 +10%/−15% Power supply unit with electrical isolation (IEC 60742, PELV)		V DC
Solenoid operating current	300		mA
Duty cycle	100		%

AS-Interface connection			
Parameter	Value		Unit
Connection	Plug connector		
Version	M12 (4-pin)		
Degree of protection according to IEC 60529	IP 67 <sup>2)</sup>		
Rated insulation voltage U	50		V AC/DC
Switching principle SK, UK	Slow-action switching element 1 NC ⇄ contact each		
EMC protection requirements	Acc. to EN 50295 (AS-Interface standard) and IEC 62026		
<b>AS-Interface data</b>			
Acc. to AS-Interface Specification 2.1	EA code: 7	ID code: B	
Total current consumption, max.	45		mA
Valid AS-Interface addresses	1 - 31		
<b>AS-Interface inputs</b>			
Version AS1	In accordance with AS-Interface Safety at Work		
	D0, D1 ▶ Door monitoring contact SK		
	D2, D3 ▶ Solenoid monitoring contact		
Version AS2	D0, D1 ▶ Positively driven contact SK 1		
	D2, D3 ▶ Positively driven contact SK 2		
<b>AS-Interface outputs</b>			
D0	Interlocking solenoid, 1 = solenoid energized		
D1	Red LED, 1 = LED on		
D2	Green LED, 1 = LED on		
AS-Interface LED Power	Green, AS-Interface Power on		
AS-Interface LED Fault	Red, offline phase or address 0		

2) Screwed tight with the related plug connector